

Image depicts Series 7508 on 8 inch IPS PVC pipe at molded PVC fitting.

Features and Applications:

- For use on IPS O.D. (Class) ASTM D2241 PVC pipe systems using molded PVC fittings.
- MEGA-BOND® Restraint Coating System For more information, refer to www.ebaa.com
- Minimum 2 to 1 Safety Factor
- Split design for ease of installation
- Constructed of ASTM A536 Ductile Iron

For use on water or wastewater pipelines subject to hydrostatic pressure and tested in accordance with either AWWA C600, C605, or ASTM D2774.

Nominal Pipe Size	Series Number	Approx. Weight	Pressure Ratings (PSI)		
			SDR17	SDR21	SDR26
2	7502	5.40	250	200	160
2½	750250	5.80	250	200	160
3	7503	6.20	250	200	160
4	7504	22.52	250	200	160
6	7506	25.56	250	200	160
8	7508	35.20	250	200	160

NOTE: For applications or pressures other than those shown, please contact EBAA for assistance.

Sample Specification

Restraint of molded PVC fittings on IPS O.D. PVC pipe (ASTM D2241) shall consist of the following: The restraint shall be manufactured of ductile iron conforming to ASTM A536. The restraint devices shall be coated using MEGA-BOND®. (For complete specifications on MEGA-BOND visit www.ebaa.com.) Side clamp bolts shall be of SAE J429 Grade 5 material. A split, non-serrated ring shall be utilized on the fitting bell. A split, serrated ring shall be used to grip the pipe, and a sufficient number of bolts shall be used to connect the bell ring to the gripping ring. The restraint shall be the Series 7500, as manufactured by EBAA Iron, Inc., or approved equal.

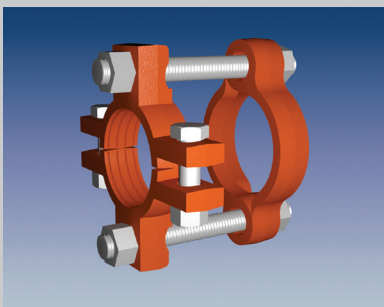

Sizes 2 - 3 inch

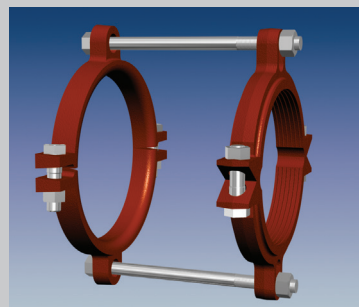

Sizes 4 - 8 inch

Series 7500 Submittal Reference Drawing

EBAA IRON

MADE IN USA

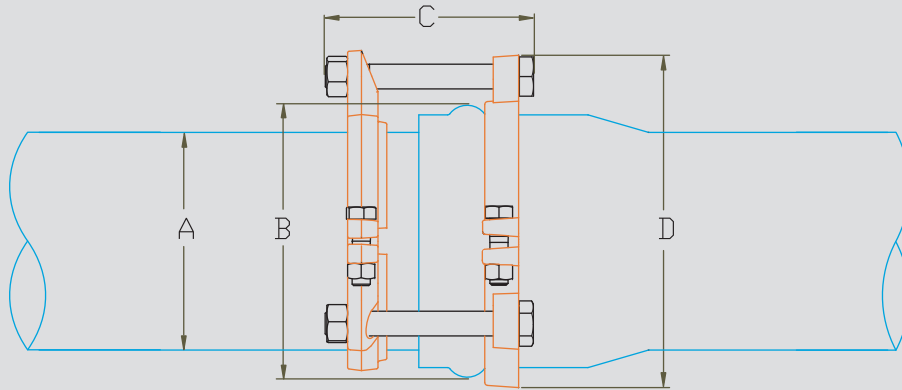

Nominal Pipe Size	Series Number	A Pipe O.D.	B Maximum Bell O.D. Cleared	C Overall Length	D Max. Restraint O.D. (Casing Clearance)	Thrust Bolt (Number - Size)
2	7502	2.38	3.56	5½	5.81	2 - 5/8 x 5½
2½	750250	2.88	4.08	5½	6.32	2 - 5/8 x 5½
3	7503	3.50	5.01	5½	7.26	2 - 5/8 x 5½
4	7504	4.50	6.98	7	10.1	2 - ¾ x 7
6	7506	6.63	9.61	7	12.6	2 - ¾ x 7
8	7508	8.63	12.50	13	14.56	3 - ¾ x 13

NOTE: Dimensions are in inches and are subject to change without notice.

Installation Instructions

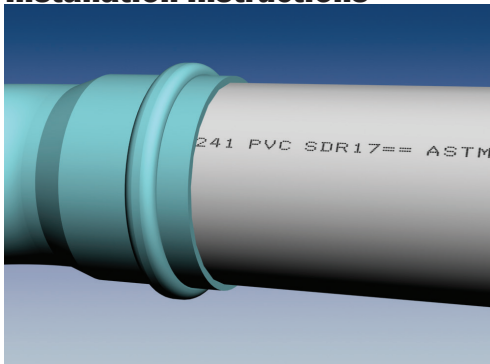

The Series 7500 is designed for restraining ASTM D2241 PVC pipe to molded PVC fittings. It has a split, serrated restraint ring on the spigot and a split non-serrated ring on the fitting.

1. Assemble the fitting per the fitting manufacturer's instructions.

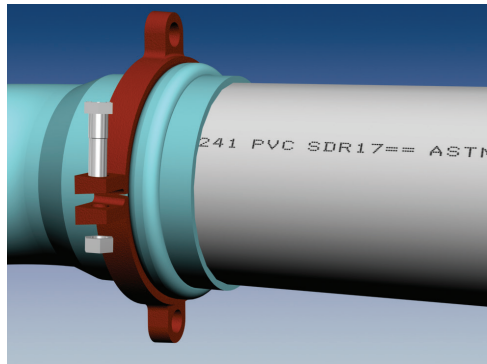

2. Install both halves of the split non-serrated bell ring on the fitting behind the gasket hump. Install the side bolts and tighten each evenly to 110 ft-lbs of torque. (40 ft-lbs on 2 inch through 3 inch, 60 ft-lbs on 4 inch through 6 inch)
3. Slide the bell ring toward the gasket hump so that it fits snugly behind the gasket hump.

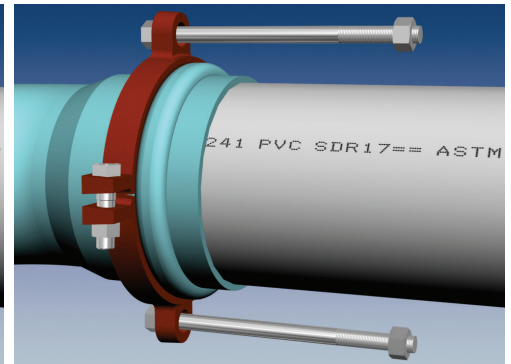

4. Remove the side bolts from the serrated restraint ring. Use the tie bolts to determine the proper location of the restraint ring on the spigot. Allow enough room on the tie bolt to fully engage the nuts.

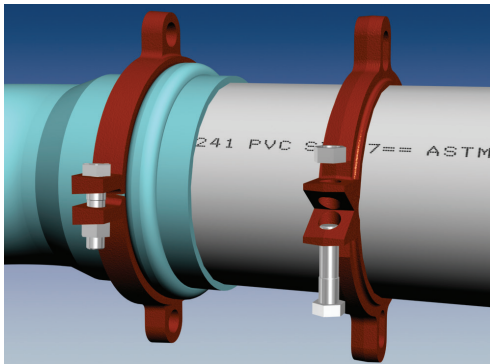

5. Install both halves of the restraint ring at the proper location, tapping each half into place. Make sure that the complete ID of the ring is touching the pipe before installing the side bolts. Tighten the side bolts evenly to 110 ft-lbs of torque. (40 ft-lbs on 2 inch through 3 inch, 60 ft-lbs on 4 inch through 6 inch)

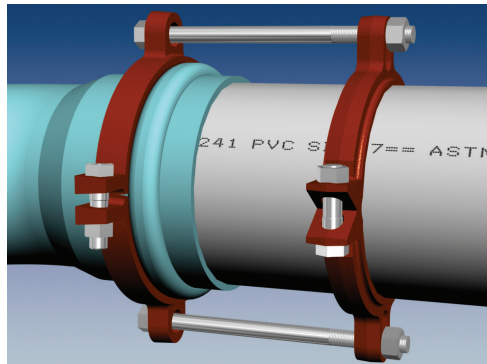

6. Place nuts on the tie bolts and tighten until they are snug. Allow enough room on the tie bolt to fully engage the nut with several threads showing. Do not tighten these bolts enough to force the spigot further into the bell of the fitting.



EBAA IRON Sales, Inc.

P.O. Box 857, Eastland, TX 76448

Tel: (254) 629-1731

Fax: (254) 629-8931

(800) 433-1716 within US and Canada

contact@ebaa.com

www.ebaa.com