

Series 1106SDB

Series 1124SDB as an anchor for connecting rods.

Features and Applications:

- For use on Ductile Iron Pipe in mid-span restraint applications
- Minimum 2 to 1 Safety Factor
- Split design for ease of installation
- Constructed of ASTM A536 Ductile Iron
- For Submittal Reference Information please refer to the Series 1100 Brochure.

For use on water or wastewater pipelines subject to hydrostatic pressure and tested in accordance with either AWWA C600 or ASTM D2774.

Wedge Impressions on DI Pipe.

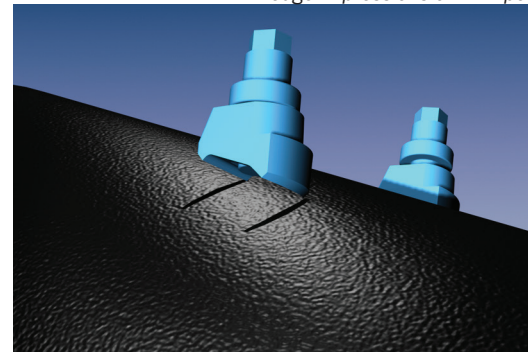

Two Series 1124SDB as an anchor in a concrete "Dead Man" wall (polyethylene wrap, not depicted, must be used. See reverse side.).

Nominal Pipe Size	Series Number	Approximate Shipping Weight	Pressure Rating (PSI)	
			Ductile Iron	Iron
3	1103SDB	9.4	350	
4	1104SDB	10.7	350	
6	1106SDB	15.1	350	
8	1108SDB	18.8	350	
10	1110SDB	38.0	300	
12	1112SDB	46.7	300	
14	1114SDB	65.7	300	
16	1116SDB	73.6	300	
18	1118SDB	80.3	200	
20	1120SDB	89.5	200	
24	1124SDB	151.6	200	
30	1130SDB	218.6	200	
36	1136SDB	258.6	200	
42	1142SDB	467.2	175	
48	1148SDB	554.1	175	
54	1154SDB	785.0	250	

NOTE: For applications or pressures other than those shown, please contact EBAA for assistance.

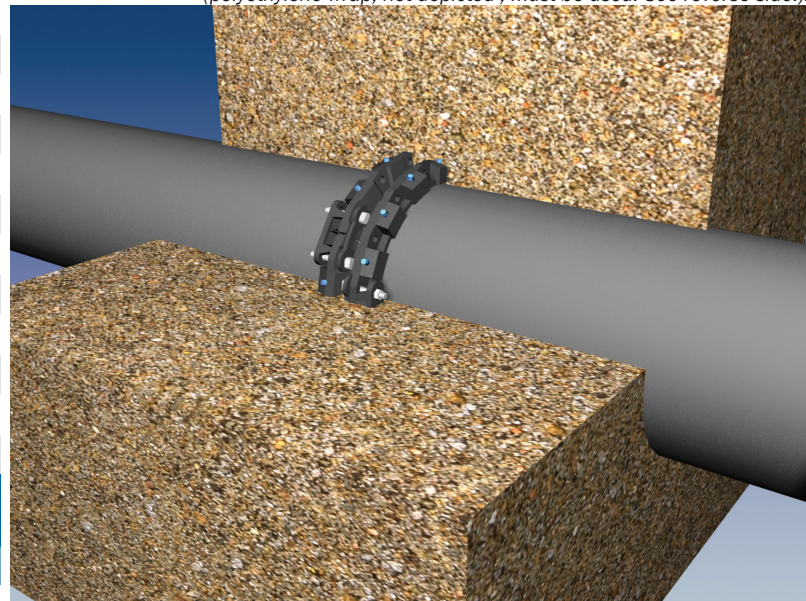

Installation Instructions for Series 1100SDB

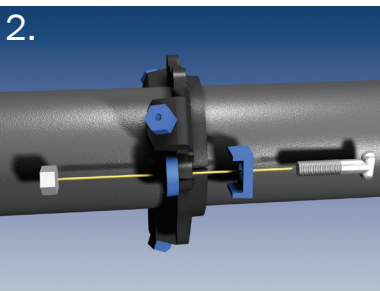
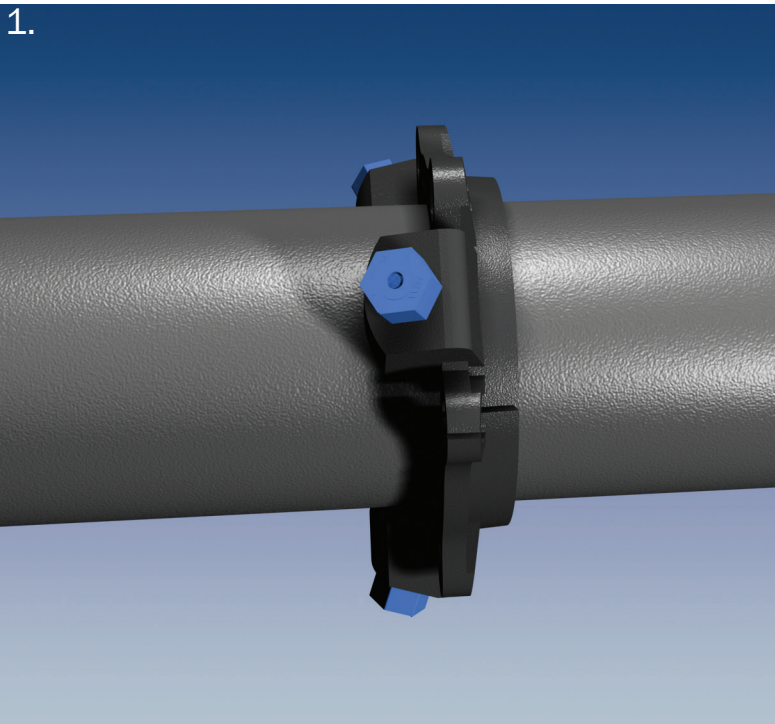

3-8 inch

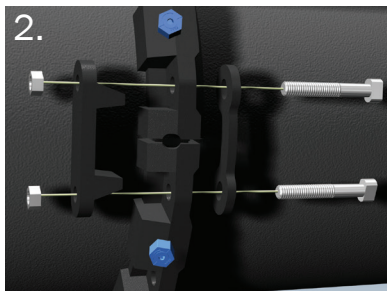

10-48 inch

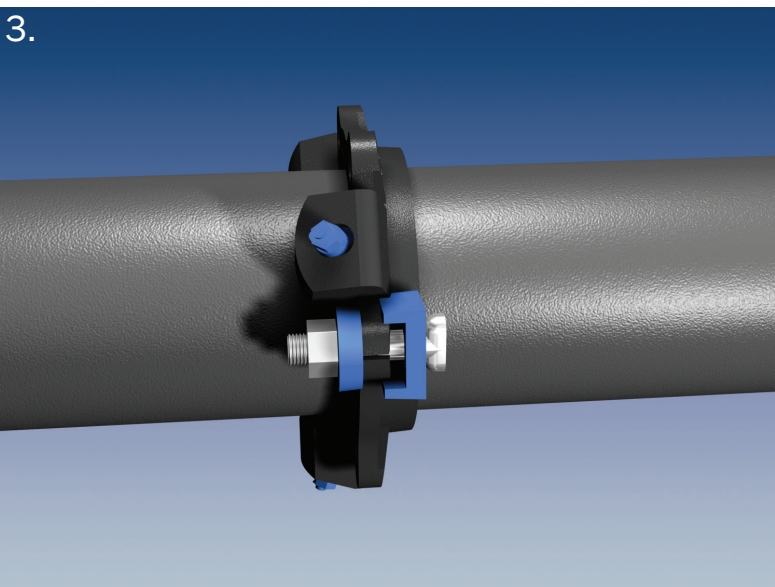

1. Remove the clamps from the split gland. Loosely assemble the halves on the pipe by assembling each clamp so that the angled surfaces of the clamp mate with the angled surfaces on each side of the split, and with the backup plate on the opposite side of the gland from the clamp. Insert the long T-bolt (provided) through the clamps and tighten hand tight.
2. Tighten the T-bolts. Tighten the bolts to the normal range of bolt torque [45-60 ft-lbs for 3 inch, 75-90 ft-lbs for 4 inch through 24 inch, 100-120 ft-lbs 30 inch through 36 inch, and 120-150 ft-lbs for 42 inch through 54 inch]. The use of a torque indicating wrench will facilitate this procedure.
3. Tighten the torque limiting twist-off nuts in a clockwise direction (direction indicated by an arrow on top of nut) until all wedges are in firm contact with the pipe surface. Continue tightening in an alternating manner until all of the nuts have twisted off.
4. If reassembly is required, assemble the joint in the same manner as above, tightening the wedge bolts to 90 ft-lbs.

Important Note:

When used as an anchor within concrete, polyethylene wrap must be used to prevent concrete intrusion into the wedge pocket.

For Submittal Reference Information please refer to the Series 1100 Brochure.



EBAA IRON Sales, Inc.

P.O. Box 857, Eastland, TX 76448

Tel: (254) 629-1731

Fax: (254) 629-8931

(800) 433-1716 within US and Canada

contact@ebaa.com

www.ebaa.com