

Series 1100HV

Restraint for Existing Push-On Joints
on Large Diameter C900 PVC Pipe

U.S. Patent Nos: 4092036, 4627774, 4779900, 5544922

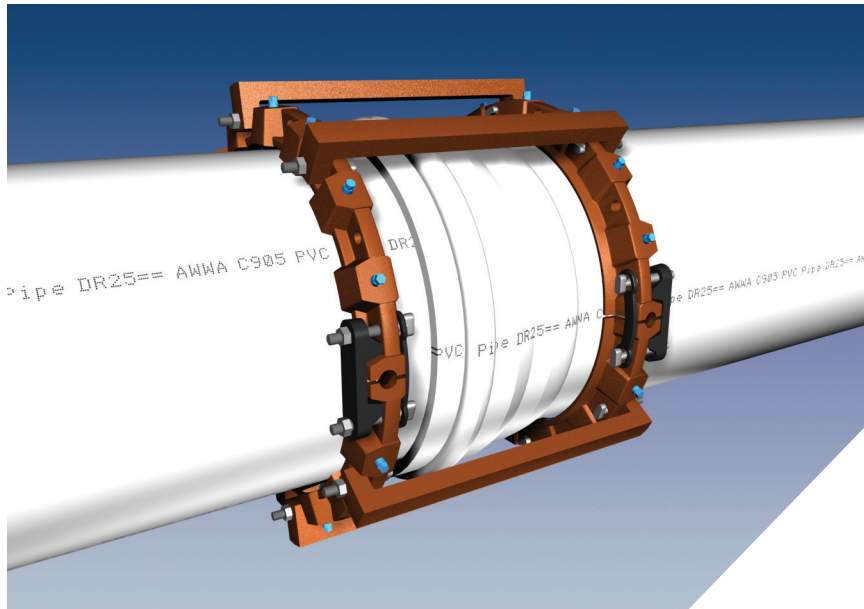

Series 1124HV on 24 inch PVC C900 Pipe.

Features and Applications:

- For use on C900 PVC Pipe at existing push-on joints
- Minimum 2 to 1 Safety Factor
- Split design for ease of installation
- **MEGA-BOND®** Restraint Coating System
For more information regarding MEGA-BOND refer to www.ebaa.com
- Constructed of ASTM A536 Ductile Iron
- For PVC use only

For use on water or wastewater pipelines subject to hydrostatic pressure and tested in accordance with either AWWA C600 or ASTM D2774

Nominal Pipe Size	Series Number	Pressure Ratings (PSI)	
		Approximate Shipping Weight	PVC Pipe (C900)
14	1114HV	211.00	150
16	1116HV	226.50	100
18	1118HV	236.40	100
20	1120HV	254.25	100
24	1124HV	364.20	100
30	1130HV	685.30	100

NOTE: For applications or pressures other than those shown, please contact EBAA for assistance.

Sample Specification

Restraint for existing bell joints found on C900 PVC pipes shall consist of the following: The restraints shall be manufactured of ductile iron conforming to ASTM A536. The split restraint rings, incorporating a plurality of individually - actuating gripping surfaces, shall be used to grip the pipe on either side of the bell. A sufficient number of tie bars casted from ASTM A536 shall be used to span the distance between the restraints and a sufficient number of bolts shall be used to connect each restraint to the tie bars. The restraint devices shall be coated using MEGA-BOND®. (For complete specifications on MEGA-BOND visit www.ebaa.com.) The combination shall have a minimum working pressure rating as shown in the adjacent table. The restraint shall be the Series 1100HV, as manufactured by EBAA Iron, Inc., or approved equal.

Packaged Items.

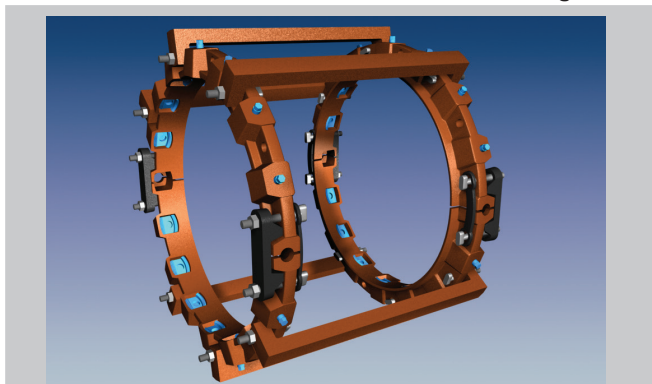

Series 1100HV Submittal Reference Drawing

EBAA IRON

MADE IN USA

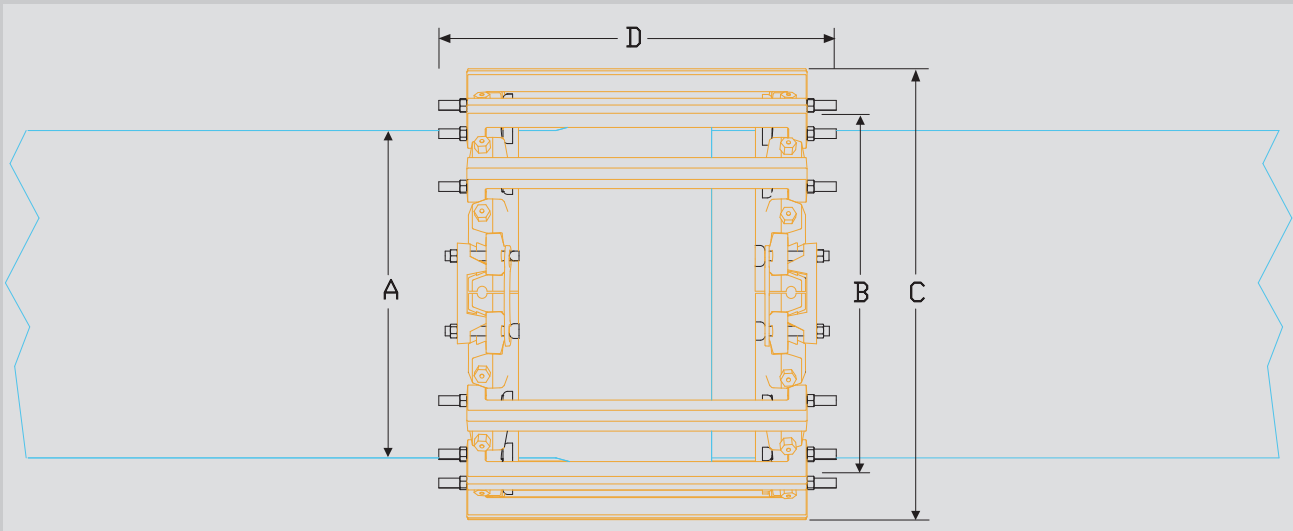

Nominal Pipe Size	Series Number	A Pipe O.D.	B Maximum Bell O.D. Cleared	C Maximum O.D. (Casing Clearance)	D Overall Length	Tie Bars (Quantity)
14	1114HV	15.30	20.25	24.25	30.00	4
16	1116HV	17.40	22.50	26.50	30.00	4
18	1118HV	19.50	24.75	28.75	30.00	4
20	1120HV	21.60	27.00	31.00	30.00	4
24	1124HV	25.80	31.50	35.50	30.00	6
30	1130HV	32.00	39.12	42.88	36.00	8

Installation Instructions

NOTE: Dimensions are in inches and are subject to change without notice.

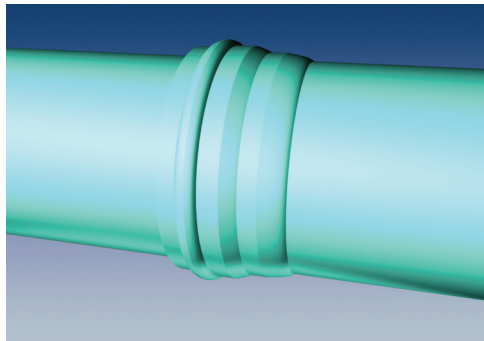

1. If joint is not so already, assemble joint per pipe manufacturer's instructions.

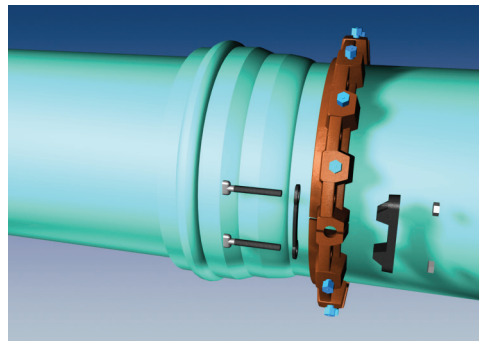

2. Disassemble one of the restraint rings. Then reassemble the halves onto the pipe bell side first using the clamp and backup plates provided. Make sure the lip of the restraint ring is facing the joint. Tighten the clamp bolts to 60 ft-lbs. At this time do not tighten the actuating gripping wedges.

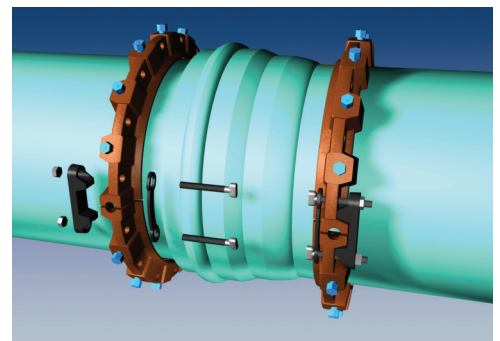

3. Disassemble the other restraint ring. Then Reassemble the halves on the spigot side of the pipe using the clamp and backup plates provided. Make sure the lip of the restraint is facing the joint. Tighten the clamp bolts to 60 ft-lbs. At this time do not tighten the actuating gripping wedges.

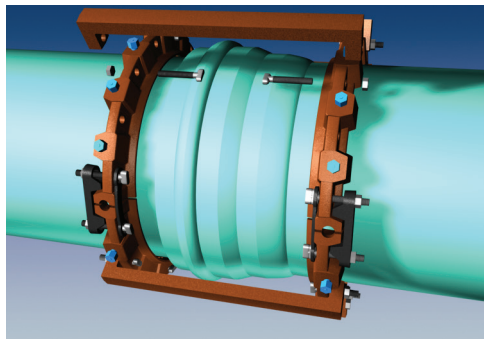

4. Line up the clamps so they are directly across from one another and slide the bell restraint snugly against the bell. Then using the bolts provided start attaching the tie bars to the restraints. The tie bar bracket should be evenly spaced on the outside of each restraint. Once the tie bars have been installed and tightened to 60 ft-lbs pull all available slack out of the harness so that the bell restraint still resides against the bell.

5. Hand tighten the actuating screws until all gripping wedges are touching the pipe evenly. Then continue to tighten in an alternating manner until the heads twist off signaling proper torques have been achieved.

6. If reinstall is necessary, retorquing the actuating screws can be done with a torque wrench and a 5/8 inch socket. Torque values are 70 ft-lbs.



EBAA IRON Sales, Inc.

P.O. Box 857, Eastland, TX 76448

Tel: (254) 629-1731

Fax: (254) 629-8931

(800) 433-1716 within US and Canada

contact@ebaa.com

www.ebaa.com